

# 3-WAY BALL VALVE TYPE23

For the Owner and the Installing Contractor

**ASAHI AV**

Serial No. :UA-007E

## User's Guide



Read and use the information contained within these documents.

This User's Guide contains very important information for the proper installation, maintenance and safe use of the 3-WAY BALL VALVE TYPE23 store in an easily accessible location.

### Warning & Caution Signs



This symbol reminds the user to take caution due to the potential for serious injury or death.



This symbol reminds the user to take caution due to the potential for damage to the valve if used in such a manner.

### Prohibited & Mandatory Action Signs



Prohibited: When operating the valve, this symbol indicates an action that should not be taken.



Mandatory action: When operating the valve, this symbol indicates mandatory actions that must be adhered to.

### General Information for Transportation, Unpacking and Storage



- This valve is not designed to handle impacts of any kind. Avoid throwing or dropping the valve.
- Avoid scratching the valve with any sharp object.
- Do not over-stack cardboard shipping boxes. Excessively stacked packages may collapse.
- Avoid contact with any coal tar creosote, insecticides, vermicides or paint. (These chemicals may cause damage to the valve.)



- Store products in their corrugated cardboard boxes. Avoid exposing products to direct sunlight, and store them indoors (at room temperature). Also avoid storing products in areas with excessive temperatures. (Corrugated cardboard packages become weaker as they become wet with water or other liquid. Take care in storage and handling.)
- After unpacking the products, check that they are defect-free and meet the specifications.

### Inspection Items



- Check for flaw, crack, or deformation on the valve.
- Check for the smoothness of handle operation.

- Check for leaks to the outside or inside.
- Inspect the cap nut and be sure it is not loose.

### General Operating Instructions



- Do not change or replace valve parts under line pressure.



- Using a positive-pressure gas with our plastic piping may pose a dangerous condition due to the repellent force particular to compressed fluids, even when the gas is under the same pressure as water. Therefore, be sure to take the necessary safety precautions such as covering the piping with protective material. For inquiries, please contact us. For conducting a leak test on newly installed piping, be sure to check for leaks under water pressure. If absolutely necessary to use gas in testing, please consult your nearest service station beforehand.
- Select a valve material that is compatible with the media, refer to CHEMICAL RESISTANCE ON ASAHI AV VALVE. (Some chemicals may damage incompatible valve materials.)



- Do not step on or apply excessive weight on valve. (It can be damaged.)
- Do not use the valve to fluid containing slurry. (The valve will not operate properly.)
- Do not use the valve in conditions where the fluid may have crystallized. (The valve will not operate properly.)



- Keep the valve away from excessive heat or fire. (It can be damaged, or destroyed.)
- Before opening or closing a lubricant free product, be sure to apply water.
- Always operate the valve within the pressure vs. temperature range. (The valve can be damaged or deformed by operating beyond the allowable range.)
- Allow sufficient space for maintenance and inspection.
- Select a valve material that is compatible with the media. For chemical resistance information, refer to "CHEMICAL RESISTANCE ON ASAHI AV VALVE". (Some chemicals may damage incompatible valve materials.)
- Keep the valve out of direct sunlight, water and dust. Use cover to shield the valve. (The valve will not operate properly.)
- Perform periodic maintenance. (Leakage may develop due to temperature changes or periods of prolonged storage, rest, or operation.)

## User's Guide

### General Operating Instructions

- Warning** -Be sure to conduct a safety check on all hand and power tools to be used before beginning work.
- Warning** -Wear protective gloves and safety goggles as fluid remain in the valve even if the pipeline is empty. (You may be injured.)
- Caution** -When installing a pipe support by means of a U-band or something similar, take care not to over-tighten. (Excessive force may damage the pipe.)
- Caution** -Take care not to over-tighten the Union Nut. (The valve can be damaged.)
- Caution** -The installed valve must never be opened or closed when foreign matter such as sand is present in the pipeline.
- Warning** -When installing pipes and valves, ensure that they are not subjected to tension, compression, bending, impact, or other excessive stress.
- When installing, disassembling, or reassembling the piping, fix the End Connector.
- Fasten the Union Nut while avoiding the parallelism and axial misalignment of the flange surface.
- When connecting an ASAHI AV Valve to metal piping, take care not to let pipe stress to ASAHI AV Valve.
- When installing a piece of equipment at the end of the piping line, be sure to keep the secondary (Downstream) End Connector and Union Nut installed on the valve.
- When loosening the cap nut on the union side, install the body cap (hold it with your hand) and perform installation accordingly. (If the body cap turns, the union will turn together, resulting in the union and ball separating from the body.) If the union is loosened, retighten the union.
- Before a water test, be sure that the Union Nut is tightly fastened.

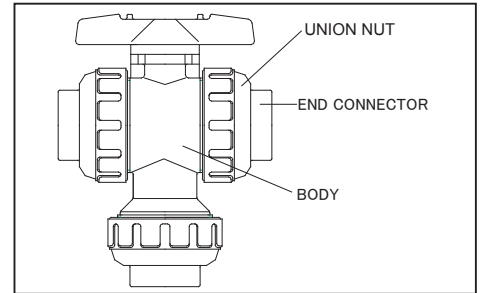

### Installation Procedure

The connection method of the 3-WAY BALL VALVE TYPE23, there are Flanged End, Socket End, Threaded End and Spigot End. Install according to the preferred method of joining for the particular application. As for details, refer to the User's manual separately.

#### Flanged End

- Caution** -The parallelism and axial misalignment of the flange surface should be under the values shown in the following table to prevent damage to the valve. (A failure to observe them can cause destruction due to stress application to the pipe)
- Use flat faced flanges for connection to AV Valves.
- Ensure that the mating flanges are of the same standards.
- Be sure to use sealing gaskets (AV Gasket), bolts, nuts, and washers and tighten them to specified torques.

1. Cleaning: Confirm the flange face area is clean and free of dirt or foreign materials.
2. Set the AV gasket between the flanges. Insert washers and bolts from the pipe side, insert washers and nuts from the valve side, then temporarily tighten them by hand. Tighten the bolts and nuts gradually with a torque wrench to the specified torque level in a diagonal manner.(Fig.1)

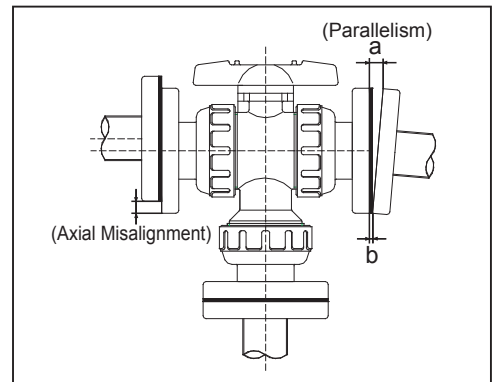
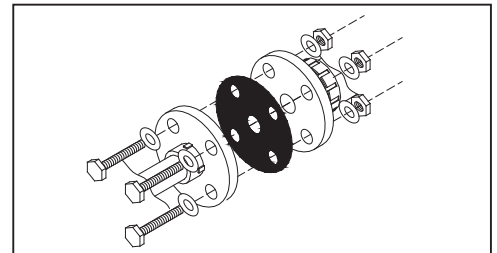

< Axial Misalignment and Parallelism of Flanged face > Unit: mm (inch)

Nom. Size	Axial Misalignment	Parallelism (a-b)
15 - 32 (1/2" - 1 1/4")	1.0 (0.04")	0.5 (0.02")
40 - 80 (1 1/2" - 3")	1.0 (0.04")	0.8 (0.03")
100 (4")	1.0 (0.04")	1.0 (0.04")

< Recommended Torque Value > Unit: N·m {kgf·cm} [lb·inch]

Nom. Size	15, 20 (1/2" - 3/4")	25 - 40 (1" - 1 1/2")	50, 65 (2", 2 1/2")	80, 100 (3" - 4")
PTFE, PVDF coated	17.5 {179} [155]	20.0 {204} [177]	22.5 {230} [200]	30.0 {306} [266]
Rubber	8.0 {82} [71]	20.0 {204} [177]	22.5 {230} [200]	30.0 {306} [266]

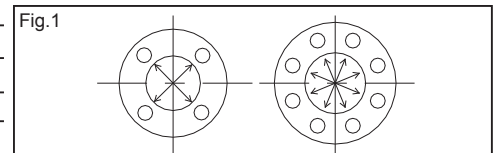

#### Socket End

#### Spigot End

1. Loosen the union nut and remove the union nut and the end connector.
2. Lead the union nut through the pipe.
3. The end connector is joined according to each joining method.

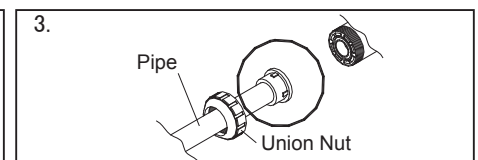
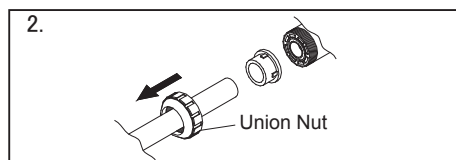
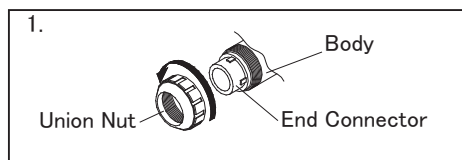

# 3-WAY BALL VALVE TYPE23







For the Owner and the Installing Contractor

## ASAHI AV

### User's Guide

Serial No. :UA-007E

#### Socket End (Material: PVC, C-PVC)

-   -When using an adhesive, ventilate the space sufficiently, prohibit the use of fire in the vicinity, and do not inhale adhesive vapors directly.
-  -If an adhesive gets into contact with your skin, wash it off immediately. If you feel sick or find any anomaly, receive a physician's diagnosis and take appropriate measures promptly.
-   -Take care in doing work at low temperatures. Solvent vapors are hard to evaporate and are likely to remain. (Solvent cracks may occur, damaging the equipment.) After assembling the piping system, open both ends of the piping and use a fan (of the Low-Voltage Type) or something similar to ventilate the space, thus removing the solvent vapors.
- Do not apply more cement than necessary. Avoid getting cement in the internals of the valve. This can cause damage to the seals and moving parts. Solvent and fumes can chemically attack the valve materials if allowed to enter the internals of the valve. (Cementing with the valve in a vertical position should be avoided)
- Do not under any circumstances try to insert a pipe into another fitting or valve by striking it, which may break the piping.
-  -Use Asahi AV cement Number-32, Number-52, or Number-62 for PVC and Number-88 for C-PVC in case of JIS Pipe & Fittings. The other standard Pipe & Fittings shall be used industrial proper PVC or C-PVC cement.
- Allow 24 hours for solvent cement to dry before performing a water leak test.

4. Entry of the Bench Mark: The bench mark indicates the maximum penetration depth of the pipe into the end connector.
5. Cleaning: Clean the hub part of the end connector by wiping with a waste cloth.
6. Application of adhesive: Apply adhesive evenly to the hub part of the end connector and the pipe spigot.
7. Insertion: After applying adhesive, insert the pipe quickly into the end connector and leave it alone for at least 60 seconds.
8. Insertion completion: Wipe away overflowing adhesive.
9. Advance to step #10.

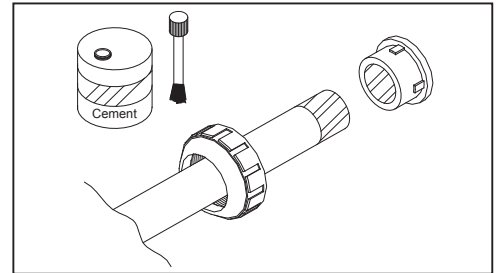



#### Socket End Spigot End (Material: PP, PVDF)

As for details, refer to the User's manual for automatic welding machine.

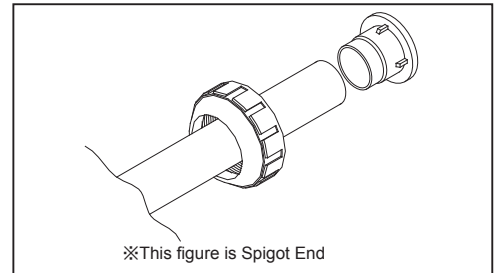
4. Preparation: Clean the hub part of the end connector by wiping with a waste cloth. Turn on the welding machine.
  - [Socket End] The bench mark indicates the maximum penetration depth of the pipe into the end connector.
5. Heating, Welding: The temperature of the heater must be confirmed with a thermometer before welding. Socket and pipe are inserted and heated for a specified time.
6. Heater removal, Connection: After the heater is removed, connect the pipe quickly to the end connector and leave it alone for a specified time.
  - [Socket End] Insertion to the bench mark.
7. Cooling: Allow appropriate time for cooling.
8. Cleaning: Clean the surface of the heating elements with a clean cloth.
9. Advance to step #10.



#### Threaded End (Material: PVC, C-PVC, PP, PVDF)

-   -Make sure that the threaded connections are plastic x plastic. (Metallic thread can cause damage.)
- Wrap the threaded joints on our plastic piping with sealing tape. Using a liquid sealing agent or liquid gasket may cause stress cracks (Environmental Stress Cracking). Our product warranty shall not apply in case of said use, even when said use is unavoidable.
- Avoid excessive tightening. (The valve can be damaged.)

1. Loosen the union nut and remove the union nut and the end connector.
2. Preparation: The seal tape is wound to the Male threaded adapter. (2 to 3 complete wraps around the male threads are sufficient.)
3. Connection: Tighten the external thread of the joint and the end connector hand tight. Using the spanner wrench, screw in the end connector by turning 180°-360°carefully without damaging it.
4. Advance to step #10.

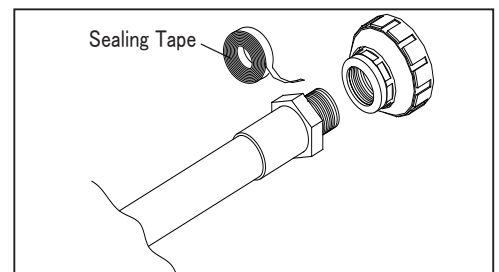

#### Socket End Threaded End Spigot End

10. Make sure that O-ring(A) is mounted.
11. Tighten union nut by hand.
12. Using a strap wrench tighten union nuts uniformly on each side approx 90° -180°, 1/4 to 1/2 turns. (Do not use pipe wrench.)

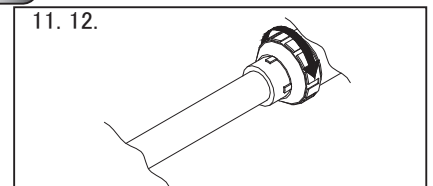
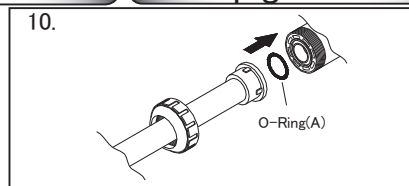

### Specification

Ball Shape	[Standard Valve] L Port (90° or 180°)			Double L Port (90°)			Cross Port (90° or 180°)				
Rotary Degree	0°	90°	180°	0°	45°	90°	0°	45°	90°	135°	180°
Flow Direction (Figure)											

### Handling of Residual and Waste Materials

Make sure to consult a waste treatment dealer for recommendations on the proper disposal of plastic valves.  
(Poisonous gas is generated when the valve is burned improperly.)

### Product Warranty

Be sure to read the following description of our product warranty.

- Always observe the specifications of and the precautions and instructions on using our product.
- We always strive to improve product quality and reliability, but cannot guarantee perfection. Therefore, should you intend to use this product with any equipment or machinery that may pose the risk of serious or even fatal injury, or property damage, ensure an appropriate safety design or take other measures with sufficient consideration given to possible problems. We shall assume no responsibility for any inconvenience stemming from any action on your part without our written consent in the form of specifications or other documented approval.
- The related technical documents, operation manuals, and other documentation prescribe precautions on selecting, constructing, installing, operating, maintaining, and servicing our products. For details, consult with our nearest distributor or agent.
- Our product warranty extends for one and a half years after the product is shipped from our factory or one year after the product is installed, whichever comes first. Any product abnormality that occurs during the warranty period or which is reported to us will be investigated immediately to identify its cause. Should our product be deemed defective, we shall assume the responsibility to repair or replace it free of charge.
- Any repair or replacement needed after the warranty period ends shall be charged to the customer.
- The warranty does not cover the following cases:
  - (1) Using our product under any condition not covered by our defined scope of warranty.
  - (2) Failure to observe our defined precautions or instructions regarding the construction, installation, handling, maintenance, or servicing of our product.
  - (3) Any inconvenience caused by any product other than ours.
  - (4) Remodeling or otherwise modifying our product by anyone other than us.
  - (5) Using any part of our product for anything other than the intended use of the product.
  - (6) Any abnormality that occurs due to a natural disaster, accident, or other incident not stemming from something inside our product.

### Inquiries

As for details, refer to the User's manual (No.H-V003E).

## ASAHI YUKIZAI CORPORATION

<http://www.asahi-yukizai.co.jp/en>

Valves and Piping System Administration

TOKYO OFFICE: 21th Floor, Ueno Frontier Tower, 24-6 Ueno 3-Chome, Taito-Ku, Tokyo, Japan 110-0005

TEL : +81-3-5826-8831 FAX : +81-3-3834-7592

BANGKOK REPRESENTATIVE OFFICE: 323 United Center Bldg, Unit 2101, 21th Floor, Silom Road, Silom, Bangrak, Bangkok 10500 THAILAND.

TEL : +66(0)2-631-1100 FAX : +66(0)2-631-1103

ASAHI KOREA CO., LTD.: #805-D Digital Empire office, 16, Deogyong-daero 1556beon-gil, Yeongtong-dong, Yeongtong-gu, Suwon-si, Gyeonggi-do, Korea

TEL : +82-31-203-2050 FAX : +82-31-203-2880

ASAHI ASIA PACIFIC PTE. LTD.: 207 Woodlands Avenue 9, #06-55, Singapore 738958

TEL : +65-6755-8033 FAX : +65-6754-7033

Asahi Organic Chemicals Trading (Shanghai) Co., Ltd.: Rm 405, East Tower, Sun Plaza NO.88 Xianxia Road, Changning District, Shanghai, China 200336

TEL : +86-21-6278-7862 FAX : +86-21-6278-7892

ASAHI AV Europe GmbH: Kaiser-Friedrich-Promenade 61 D-61348 Bad Homburg Germany

TEL : +49-6172-9175-0 FAX : +49-6172-9175-25

ASAHI /AMERICA, INC.: 655 Andover, St. Lawrence, MA 01843 USA

TEL : +1-781-321-5409 FAX : +1-978-685-3010