

REV	DATE	DESCRIPTION	BY	FROM
E	8/4/21	RE-DRAWN IN SW, ADD 2.5" & 5"	JO	DH
F	9/21/21	CHG ITEM 19 MATERIAL TO 316SS	JO	DH

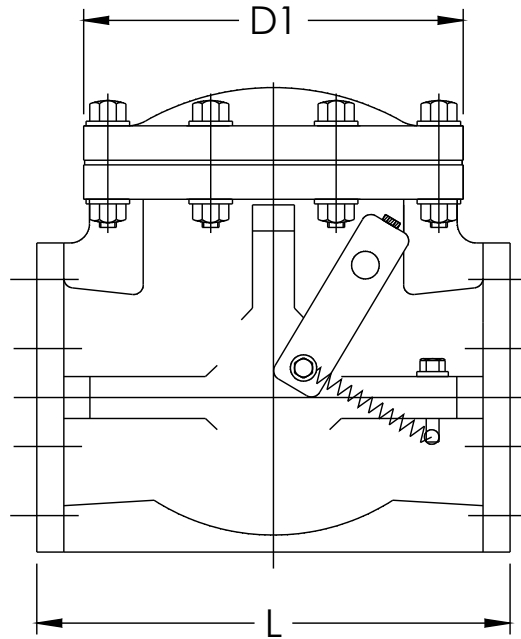
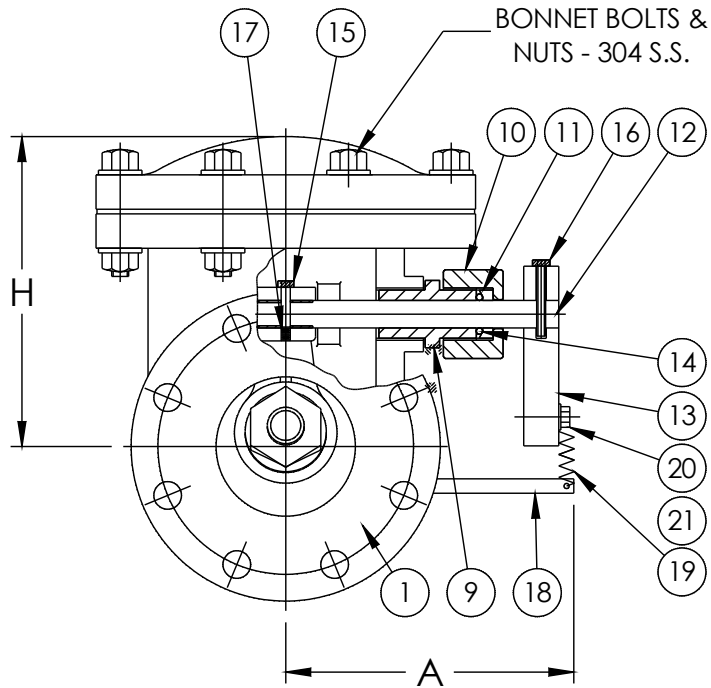

NOMINAL SIZE		L	A	D1	H	
INCH	mm				PVC, PP	PVDF
3/4"	20mm	5.51	4.00	3.39	3.43	3.54
1"	25mm	6.30	4.50	5.12	4.72	4.72
1-1/2"	40mm	7.09	5.00	5.71	5.43	5.43
2"	50mm	7.87	5.50	7.09	6.46	6.46
2-1/2"	65mm	9.45	6.00	7.87	6.61	6.61
3"	80mm	10.24	6.50	8.07	6.73	6.73
4"	100mm	11.81	8.00	10.43	8.39	8.39
5"	125mm	13.78	10.00	12.99	9.76	9.76
6"	150mm	15.75	10.50	14.57	11.14	11.14
8"	200mm	19.69	12.00	16.73	13.23	13.23

ITEM #	DESCRIPTION	QTY	MATERIAL	REMARKS
21	WASHER	1	STAINLESS STEEL 316	
20	SH CAP SCREW	1	STAINLESS STEEL 316	
19	SPRING	1	STAINLESS STEEL 316	
18	ROD	1	STAINLESS STEEL 316	
17	THREADED INSERT	1	STAINLESS STEEL 316	
16	SH CAP SCREW	-	STAINLESS STEEL 316	
15	SH CAP SCREW	-	STAINLESS STEEL 316	
14	O-RING	1	<input type="checkbox"/> EPDM <input type="checkbox"/> OTHERS	
13	SPRING ARM	1	PVC	
12	SHAFT	1	STAINLESS STEEL 316	
11	SPACER	1		
10	NUT	1	<input type="checkbox"/> PVC <input type="checkbox"/> OTHER	
9	FITTING	1		
1	SWING CHECK VALVE	1	<input type="checkbox"/> PVC <input type="checkbox"/> PP <input type="checkbox"/> PVDF <input type="checkbox"/> OTHER	

NOTES:

- SHAPE AND APPEARANCE OF ASSEMBLY DIFFER A LITTLE WITH NOMINAL SIZE COMPARED TO THIS DRAWING

UNLESS OTHERWISE SPECIFIED	
DIMENSIONS ARE IN INCHES	
MACHINING TOLERANCES:	2 PL DECIMALS ±.01 3 PL DECIMALS ±.005
FRACTIONAL	± 1/2" ± 1/64
FABRICATION TOLERANCES PER PIPE Ø:	1/2" - 8" ± 1/4 10" AND UP ± 1/2 ANGULAR ± 1.0°
WELD TYPE:	N/A
MATERIAL:	AS NOTED
FINISH:	125µ"

THIS DRAWING AND ALL INFORMATION HEREIN IS THE PROPERTY OF ASAHI/AMERICA. ANY COPYING, REPRODUCTION OR UNAUTHORIZED USE IS FORBIDDEN WITHOUT WRITTEN CONSENT.		
NAME	DATE	
DR	J. O'Connor 08/04/21	
REV		
APPR	D. Hurley 09/21/21	
PRODUCT:	VALVE & ACT	
WO#/SO#		

ASAHI/AMERICA
ISO 9001 CERTIFIED
655 ANDOVER STREET, LAWRENCE, MA



SWING CHECK VALVE WITH SPRING ASSIST 3/4" THRU 8"

JDE PART # 0028CH

SIZE **A** DWG # **0028CH** REVISION **F**

SCALE N/A SHEET 1 OF 1