

Series 17 Multi-volt Electric Actuator



Installation, Operation and Maintenance Manual



Table of Contents

Series 17 Multi-volt Electric Actuator Introduction.....	3
Description	3
Electrical Requirement	3
Installation	4
Series 17 Electric Actuator	4
Type 21 Ball Valve/Type 57 Butterfly Valve.....	4
Type 23 Ball Valve	4
Operation	4
Manual Override Operation	4
Setting Limit Switches	5
Maintenance.....	6
Troubleshooting.....	7

Series 17 Multi-volt Electric Actuator Introduction

Description

The Series 17 electric actuator features a reversing motor with multi-voltage capabilities; 85vac-265vac (50/60Hz), 24vdc. An internal heater, auxiliary switches, and two position indicating LED's, are standard equipment. Additional features include a permanently lubricated steel gear train, NEMA Type 4 & 6 enclosure with a thermally bonded powder coat finish, declutchable manual override, visual mechanical position indication, ISO bolt circle, and flying leads.

Additional options are not available for the Series 17

The Series 17 is a compact, light weight, 90 degree electric actuator specifically manufactured for on/off ball valves up to a 2" line size, and on/off butterfly valves up to a 3" line size. The auxiliary switches are SPDT and rated for 5A, and the position indicating LED's are color coded as GREEN for closed and RED for open.

Electrical Requirement

WARNING: Do not open actuator cover while circuits are energized.



Torque (in/lbs)	110 Vac		220 Vac		24 Vdc		Cycle Time per 90 Degrees (Seconds)	Weight (Pounds)
	Amp Draw	Duty Cycle	Amp Draw	Duty Cycle	Amp Draw	Duty Cycle		
350	0.12	70%	0.06	70%	0.46	70%	12	2.7

NOTE: Amp rating is considered running.
Duty cycles are for ambient temperature (73°F)

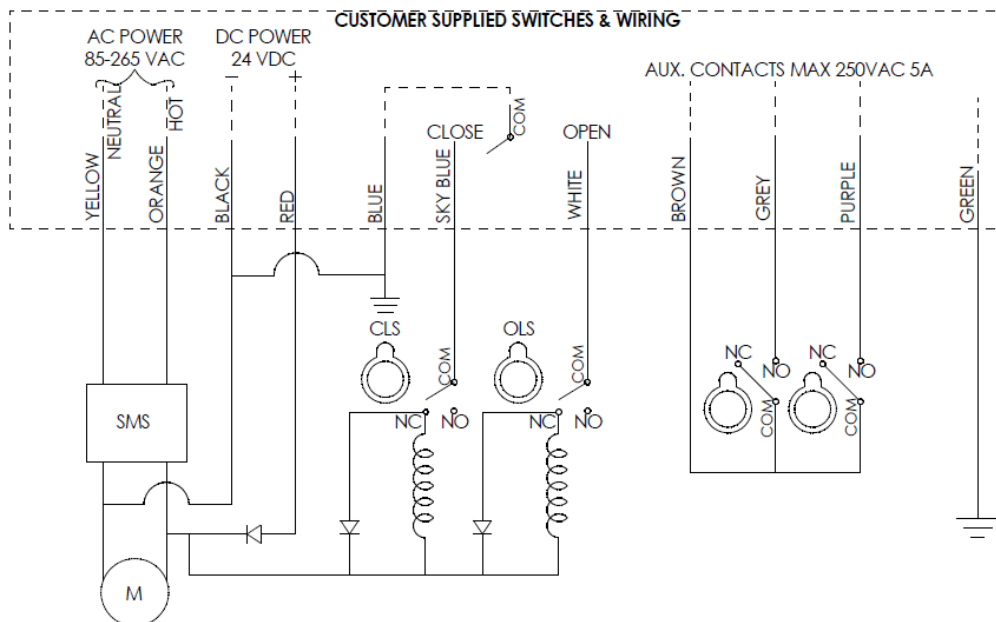

Installation

Series 17 Electric Actuator

The Series 17 electric actuator has a sealed cable gland with 1.2M flying leads. The electrician is required to make field connections as per the wiring schematic shown in this manual while following local and/or Agency wiring practices.

Note: *Not all wires provided will be used. Reference drawing number 2049900*

Type 21 Ball Valve/Type 57 Butterfly Valve

Reference drawing numbers M00BV9886 & M00BV9918

Position the valve and the actuator to corresponding positions (both are OPEN, or both are CLOSED).

Install mounting bracket to actuator so that the solid side of the bracket is in line with the actuator cable gland. Use bolts and washers to tighten. Insert coupling on stem of valve and then bolt valve to mounting bracket making sure that the cable gland will be over pipeline. Tighten up using bolts nuts and washers.

Note: *All bolts should be snug and not excessively over tightened.*

Type 23 Ball Valve

Reference drawing number M00BV9921

Double L ball to be orientated so that (when viewed from the top) the left port is open (9:00 position) while the second hole of the ball is in the 12:00 position.

Ensure that the actuator is in the open position, then install mounting bracket to actuator so that the solid side of the bracket is in line with the actuator cable gland. Use bolts and washers to secure. Insert coupling on stem of valve and then bolt valve to mounting bracket making sure that the open port (9:00) is located at actuator cable gland. Tighten up using bolts, nuts, and washers. Unit will operate as OPEN being open port at cable gland, and CLOSE being open port opposite cable gland.

Note: *All bolts should be snug and not excessively over tightened.*

Operation

Manual Override Operation

Remove manual override lever from storage position located on the bottom of actuator by loosening two Phillips head screws; handle will then slide out. Be careful not to damage threads on end of manual override lever. Thread manual override lever into designated area on actuator base (see below).

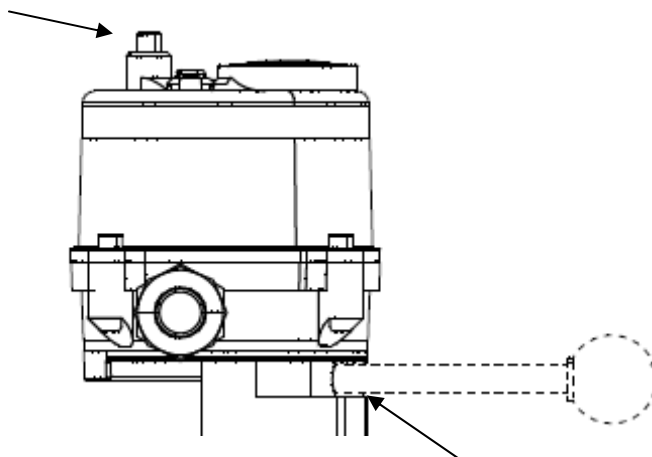

To operate the manual override, push down on rubber booted button located on top of actuator. While holding this button down, the manual override lever can be rotated to manually cycle valve (CCW to open, CW to close). When finished using the manual override it is imperative to remove the lever and place it back into storage on actuator base and tighten up the Allen head screws.

CAUTION: The manual override should only be used when there is no power applied to actuator. When power is restored the actuator will automatically resume normal operation.

Setting Limit Switches



Disconnect power!

To gain access to the limit switches it is first necessary to remove cover

Remove rubber grommet from manual override push button located on top of actuator; set aside but do not lose. Loosen four cover screws and lift off cover. Remove manual override lever from storage and insert into actuator as detailed in Manual Override Section.

Close Travel Limit Switch (Green cam/CLS):

Using declutchable manual override, move the valve to a full closed position, loosen set screw on green cam and rotate cam (CW) into limit switch arm until a click is heard, this designates the switch circuit has opened and defines a full closed position. Tighten set screws on Green cam and confirm position.

Close Auxiliary Limit Switch (Black cam/ACLS):

While actuator is in the full closed position, loosen set screw on Black cam and rotate cam (CW) into limit switch arm until a click is heard, continue to rotate a few more degrees as Auxiliary switch **MUST** be tripped before Travel switch. Tighten set screw on Black cam and confirm position.

Open Travel Limit Switch (Red cam/OLS):

Using declutchable manual override, move the valve into a full open position. Then loosen set screw on Red cam and rotate cam (CCW) into limit switch arm until a click is heard, this designates the switch circuit has opened and defines a full open position. Tighten set screw on Red cam and confirm position.

Open Auxiliary Limit Switch (White cam/AOLS):

While actuator is in the full open position, loosen set screw on White cam and rotate cam (CCW) into limit switch arm until a click is heard, continue to rotate a few more degrees as Auxiliary switch **MUST** be tripped before Travel switch. Tighten set screw on White cam and confirm position.

Return Manual Override Lever to storage as detailed in Manual Override Section. Cover unit and install rubber grommet on to manual override push button located on top of actuator.

Maintenance

Disconnect power!



WARNING: Do not open actuator cover while circuits are energized.

CAUTION: It is imperative for reducing the chance of electrical shock, and to prevent ignition of hazardous atmospheres that you

Disconnect power

before any maintenance or repairs are performed.

Series 17 actuators should be on a 6-month maintenance schedule for the following checks:

- Ensure that actuator is properly aligned
- Ensure that wiring has not been compromised
- Ensure that all fasteners are present and tight
- Ensure that cover o-rings and seals are not dried out or damaged
- Ensure that manual override works properly

Troubleshooting

WARNING: Do not open actuator cover while circuits are energized.

Q: *What if valve does not cycle?*

A: No power source to actuator. Check for power.

A: Power source disconnected. Check for broken wire, loose connection or no connection as per appropriate wiring diagram.

A: Low or incorrect power source. Check for proper voltage.

A: Unit incorrectly wired. Confirm wiring

A: Confirm limit switch cams are set properly

Q: *What if motor hums and no output is observed?*

A: Foreign material caught in valve. Remove material and inspect valve for damaged and/or worn parts. Replace parts as necessary.

A: Unit wired incorrectly (simultaneously powering open and closed). Check wiring as per appropriate wiring diagram.

Attachments:

5 drawings: 2049900, M00BV9886, M00BV9921, M00BV9918 & M00BV9915

REV	DATE	DESCRIPTION	BY	FROM
A	3/28/17	FIRST ISSUE	CW	MW

CUSTOMER SUPPLIED SWITCHES & WIRING

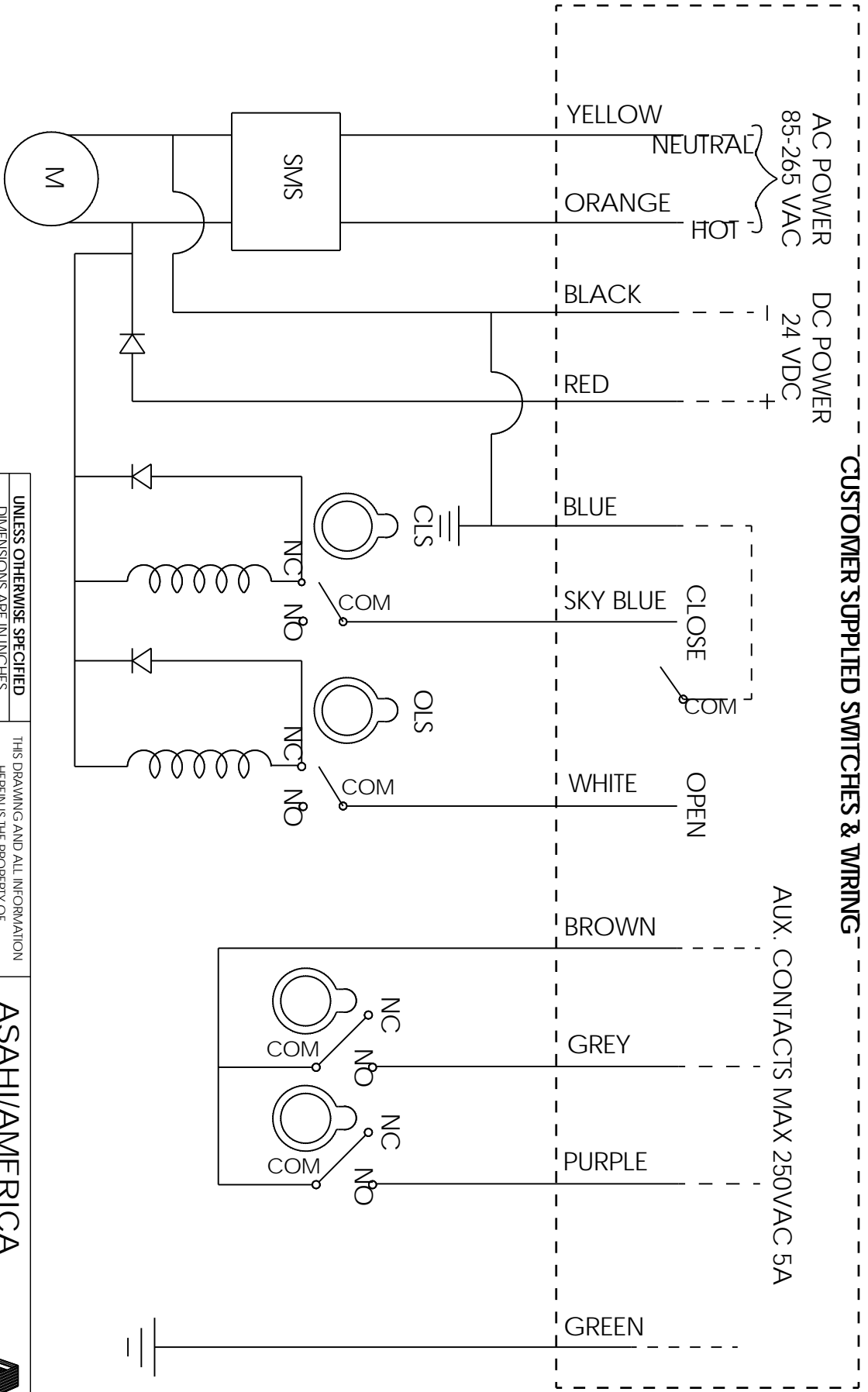

AUX. CONTACTS MAX 250VAC 5A

UNLESS OTHERWISE SPECIFIED

DIMENSIONS ARE IN INCHES

MACHINING: 2 PL. DECIMALS ± .01
3 PL. DECIMALS ± .005

TOLERANCES:

ANGULAR: ± 1/2°
FRACTIONAL: ± 1/64
1/2" - 8": ± 1/4
10" AND UP: ± 1/2
ANGULAR: ± 1.0°

FABRICATION: 10" AND UP ± 1.0°
TOLERANCES: ANGULAR

WEILD TYPE: N/A

MATERIAL: N/A

FINISH: N/A

THIS DRAWING AND ALL INFORMATION HEREIN IS THE PROPERTY OF ASAHI/AMERICA. ANY COPYING, REPRODUCTION OR UNAUTHORIZED USE IS FORBIDDEN WITHOUT WRITTEN CONSENT.

REV	NAME	DATE
DR	C. Williams	04/07/17
APPR	M. Willen	10/17/17

PRODUCT: VALVE & ACT

WO#/SO#: N/A

ASAHI/AMERICA
ISO 9001 CERTIFIED
655 ANDOVER STREET, LAWRENCE, MA

SERIES 10-04P WIRING DIAGRAM

JDE PART # 2049900

SCALE: N/A

SIZE: A DWG # 2049900

SHEET 1 OF 1

REVISION: A



VALVE SIZE	H	H1
1/2"	2.76	1.14
3/4"	3.01	1.38
1"	3.29	1.54
1-1/4"	3.64	1.85
1-1/2"	3.98	2.17
2"	4.43	2.60

REV	DATE	DESCRIPTION	BY	FROM
A	3/28/17	FIRST ISSUE	CW	MW

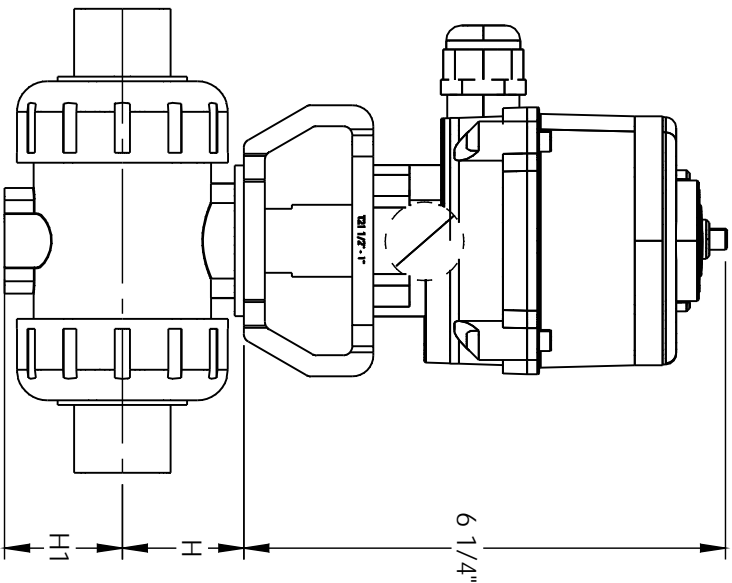
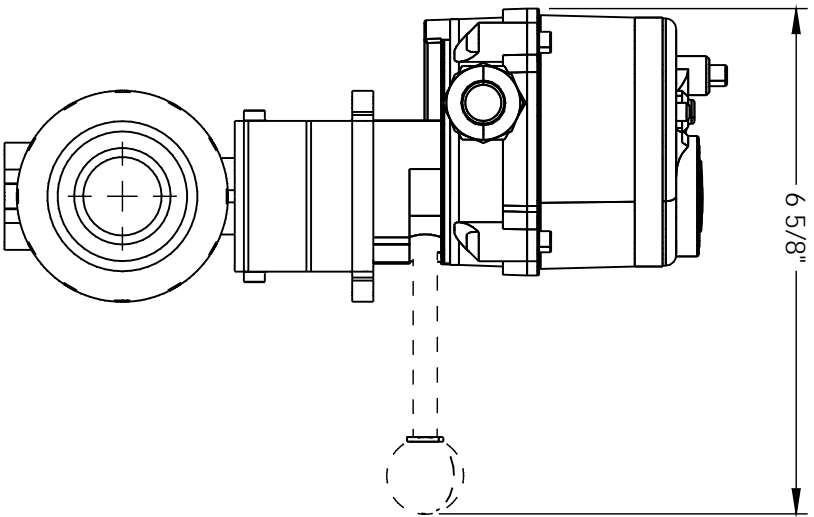

UNLESS OTHERWISE SPECIFIED

DIMENSIONS ARE IN INCHES

MACHINING 2 PL. DECIMALS ± .01

TOLERANCES: 3 PL. DECIMALS ± .005

ANGULAR ± 1/2°

FRACTIONAL ± 1/64

FABRICATION 1/2" - 8" ± 1/4

TOLERANCES: 10" AND UP ± 1/2

ANGULAR ± 1.0°

WEILD TYPE: N/A

MATERIAL: N/A

FINISH: N/A

THIS DRAWING AND ALL INFORMATION HEREIN IS THE PROPERTY OF ASAH/AMERICA. ANY COPYING, REPRODUCTION OR UNAUTHORIZED USE IS FORBIDDEN WITHOUT WRITTEN CONSENT.

REV	NAME	DATE
DR	C. Williams	04/03/17
APPR	M. Willen	10/17/17

PRODUCT: VALVE & ACT

WO#/SO# N/A

ASAH/AMERICA
ISO 9001 CERTIFIED
 655 ANDOVER STREET, LAWRENCE, MA

SERIES 17 TO 1/2" - 2" T-21 BALL VALVE

JDE PART # M00BV9886

SIZE **A** DWG # **M00BV9886** REVISION **A**

SCALE N/A SHEET 1 OF 1

VALVE SIZE	H	H1
1/2"	2.76	3.05
3/4"	3.01	3.56
1"	3.29	4.34
1-1/2"	3.98	6.09
2"	4.43	6.87

REV	DATE	DESCRIPTION	BY	FROM
A	1/11/18	FIRST ISSUE	FC	KB

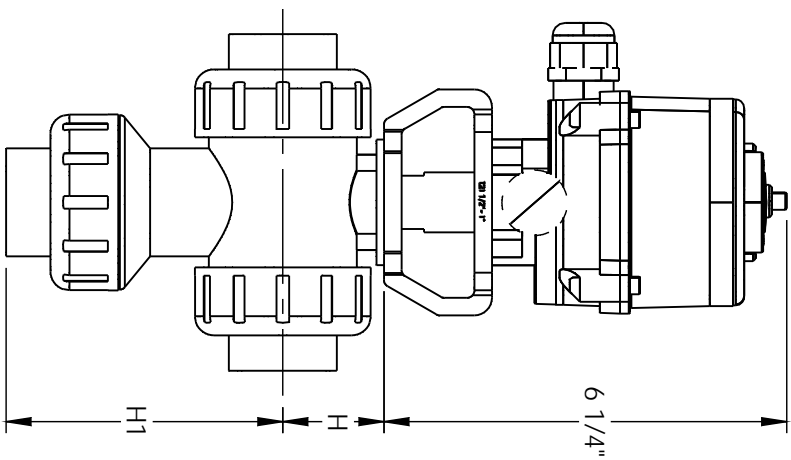
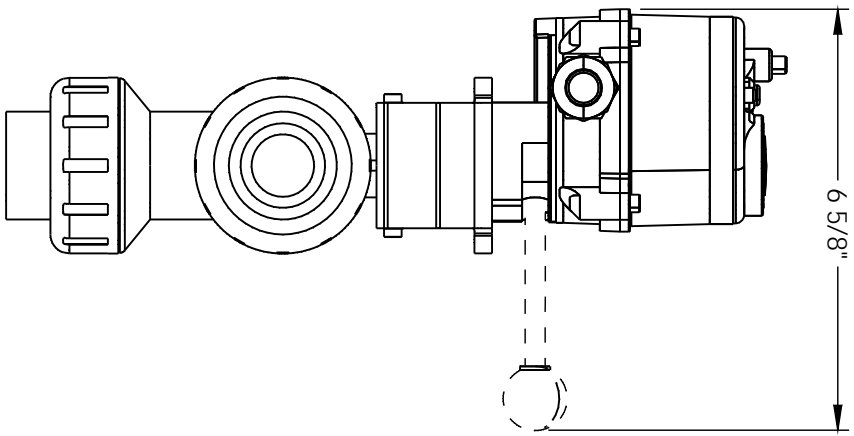

UNLESS OTHERWISE SPECIFIED

DIMENSIONS ARE IN INCHES
 MACHINING 2 PL. DECIMALS ± .01
 TOLERANCES: 3 PL. DECIMALS ± .005

FABRICATION 1/2" ± 1/4
 TOLERANCES: 10' AND UP ± 1/2
 ANGULAR ± 1.0°

WEILD TYPE: N/A
 MATERIAL: N/A
 FINISH: N/A

THIS DRAWING AND ALL INFORMATION

HEREIN IS THE PROPERTY OF
 ASAHII/AMERICA. ANY COPYING,
 REPRODUCTION OR UNAUTHORIZED USE
 IS FORBIDDEN WITHOUT WRITTEN CONSENT.

NAME	DATE
F. Catizone	01/11/18
DR	
REV	
APPR	01/11/18
PRODUCT:	VALVE & ACT
WO#/SO#	N/A

ASAHII/AMERICA
ISO 9001 CERTIFIED
 655 ANDOVER STREET, LAWRENCE, MA

SERIES 17 TO 1/2" - 2" T-23 BALL VALVE



JDE PART #	M00BV9921
SIZE	A
DWG #	M00BV9921
SCALE	N/A
SHEET	1 OF 1
REVISION	A

VALVE SIZE	H	H1
1-1/2"	5.51	2.95
2"	5.75	3.25
2-1/2"	6.18	3.64
3"	6.46	4.15

REV	DATE	DESCRIPTION	BY	FROM
A	12/18/17	FIRST ISSUE	FC	KB

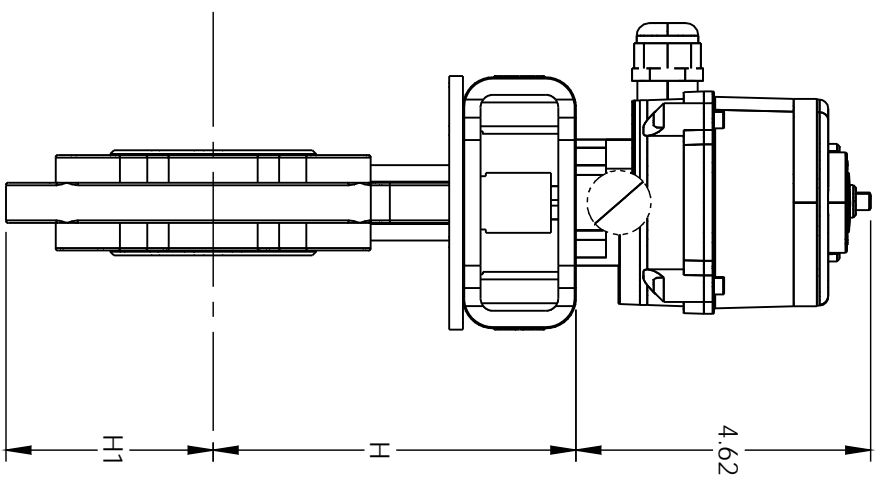
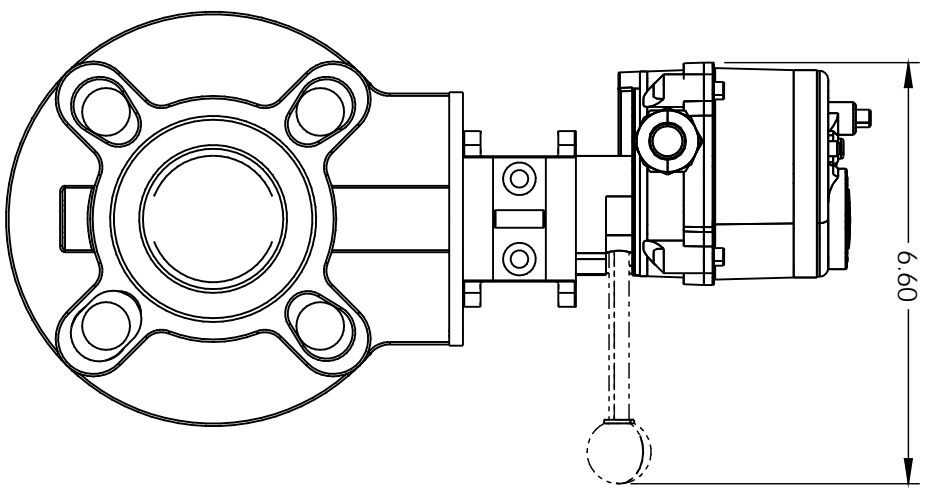

UNLESS OTHERWISE SPECIFIED

DIMENSIONS ARE IN INCHES

MACHINING 2 PL. DECIMALS ± .01

TOLERANCES: 3 PL. DECIMALS ± .005

ANGULAR ± 1/2°

FRACTIONAL ± 1/64

FABRICATION 1/2" - 8" ± 1/4

TOLERANCES: 10" AND UP ± 1/2

ANGULAR ± 1.0°

WELD TYPE: N/A

MATERIAL: N/A

FINISH: 125μ"

THIS DRAWING AND ALL INFORMATION HEREIN IS THE PROPERTY OF ASAHII/AMERICA. ANY COPYING, REPRODUCTION OR UNAUTHORIZED USE IS FORBIDDEN WITHOUT WRITTEN CONSENT.

APPR	K. Blystone	12/18/17
REV	F. Catizone	12/18/17
DR		
PRODUCT:	VALVE & ACT	
WO#/SO#		

ASAHII/AMERICA
ISO 9001 CERTIFIED
 655 ANDOVER STREET, LAWRENCE, MA



SERIES 17 TO 1-1/2" - 3" T-57 BUTTERFLY VALVE

JDE PART # M00BV9918

SIZE **A** DWG # **M00BV9918** REVISION **A**

SCALE N/A SHEET 1 OF 1

REV	DATE	DESCRIPTION	BY	FROM
A	11/10/17	FIRST ISSUE	JH	KB

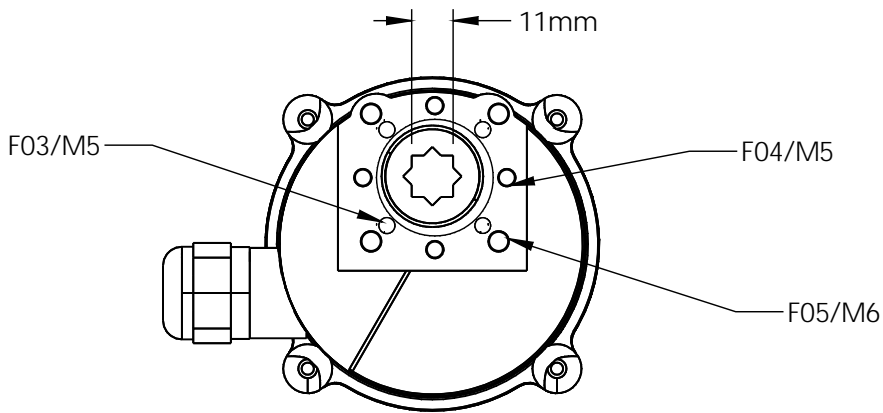
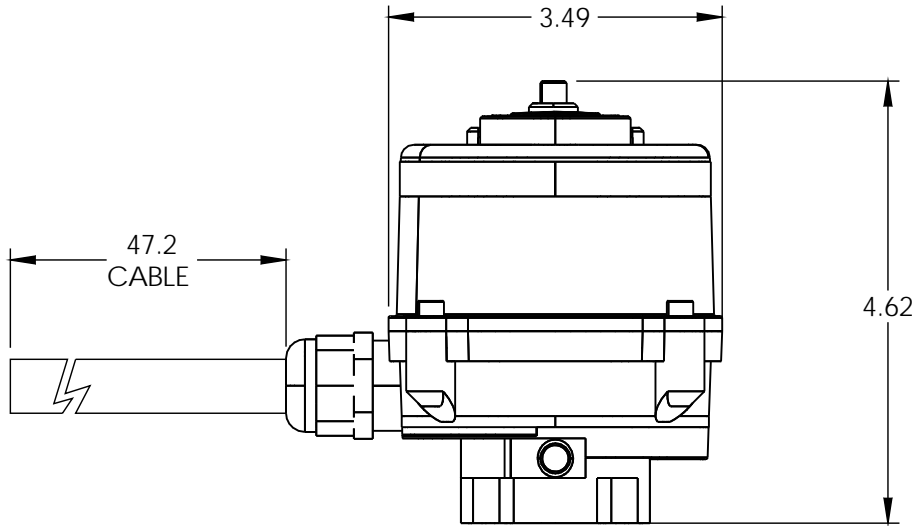
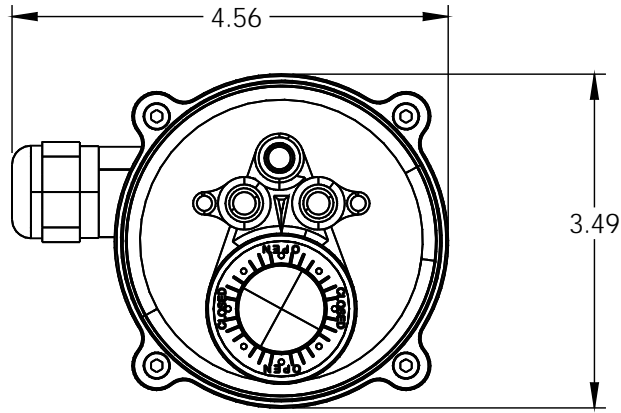

UNLESS OTHERWISE SPECIFIED DIMENSIONS ARE IN INCHES		THIS DRAWING AND ALL INFORMATION HEREIN IS THE PROPERTY OF ASAHI/AMERICA. ANY COPYING, REPRODUCTION OR UNAUTHORIZED USE IS FORBIDDEN WITHOUT WRITTEN CONSENT.		ASAHI/AMERICA ISO 9001 CERTIFIED 655 ANDOVER STREET, LAWRENCE, MA						
MACHINING	2 PL DECIMALS ± .01			SERIES 17 DIMENSIONS						
TOLERANCES:	3 PL DECIMALS ± .005									
	ANGULAR ± 1/2°									
	FRACTIONAL ± 1/64									
FABRICATION	1/2" - 8" ± 1/4									
TOLERANCES:	10° AND UP ± 1/2	DR	J. Hughes							
	ANGULAR ± 1.0°	REV								
WELD TYPE:	N/A	APPR	K. Blystone	JDE PART #		2049900				
MATERIAL:	N/A	PRODUCT:	VALVE & ACT	SIZE	A		DWG #	M00BV9915	REVISION	A
FINISH:	125μ"	WO#/SO#		SCALE	N/A		SHEET 1 OF 1			