

SHUT

OPEN

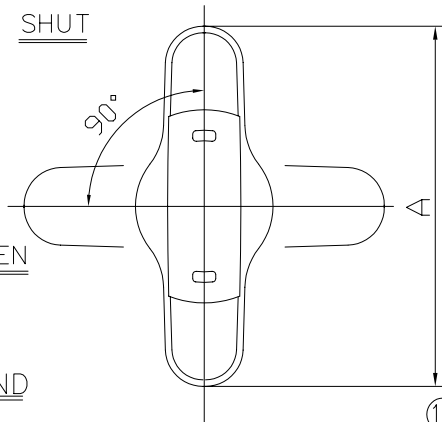

DIMENSIONS TABLE

UNIT: INCH

NOMINAL SIZE	d	FLANGED						SOCKET				THREADED			D ₁	H	H ₁	A	S ₁	S ₂	S ₃	
		ANSI CLASS 150						PVC, CPVC				d ₁	l	L								
		D	C	n	h	L	t	ANSI SCH80		L												
1/2"	15 ^{mm}	0.59	3.50	2.38	4	0.62	5.63	0.47	0.848	0.836	0.875	4.45	1/2 -14 NPT	0.59	4.02	1.89	2.03	1.14	3.62	0.75	0.29	0.43
3/4	20	0.79	3.88	2.75	4	0.62	6.77	0.55	1.058	1.046	1.000	5.08	3/4 -14 NPT	0.67	4.72	2.36	2.34	1.38	3.94	0.75	0.29	0.43
1	25	0.98	4.25	3.12	4	0.62	7.36	0.55	1.325	1.310	1.125	5.75	1 -11 1/2 NPT	0.79	5.16	2.76	2.68	1.54	4.33	0.75	0.29	0.43
1 1/4	32	1.26	4.62	3.50	4	0.62	7.48	0.63	1.670	1.655	1.250	6.46	1 1/4 -11 1/2 NPT	0.87	5.91	3.23	3.17	1.85	4.76	1.18	0.35	0.59
1 1/2	40	1.57	5.00	3.88	4	0.62	8.35	0.63	1.912	1.894	1.375	7.24	1 1/2 -11 1/2 NPT	0.98	6.42	3.94	3.50	2.17	5.16	1.18	0.35	0.59
2	50	2.01	6.00	4.75	4	0.75	9.21	0.63	2.387	2.369	1.500	8.23	2 -11 1/2 NPT	1.10	7.76	4.96	4.04	2.60	6.26	1.18	0.35	0.59

NOTE. The shape and appearance of assembly differ a little with nominal size compared to this drawing.

FLANGED END

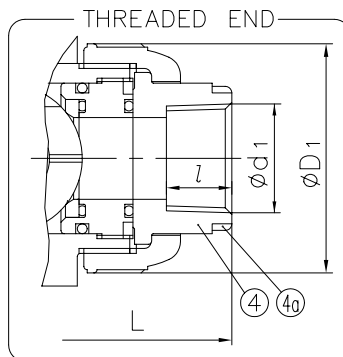
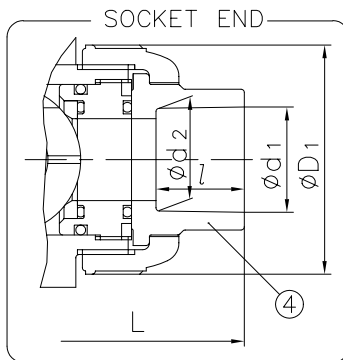
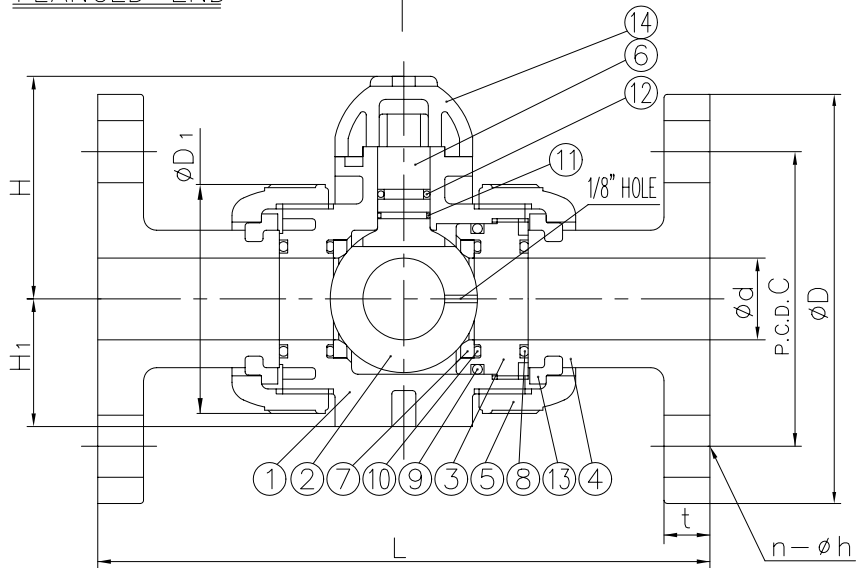

FOR REFERENCE ONLY
ASAHI/AMERICA

No.	DESCRIPTION	No.REQ'D	MATERIAL	REMARKS
4a	RING	2	STAINLESS STEEL 304	Used for CPVC Body, Threaded End: 1/2"~1"
14	HANDLE	1	ABS	
13	STOP RING	2	PVDF	Used for Flanged End
12	O-RING (E)	1	□EPDM	
11	O-RING (D)	1	□FKM	
10	O-RING (C)	2	□Others	
9	O-RING (B)	1	()	
8	O-RING (A)	2		
7	SEAT	2	PTFE	
6	STEM	1		
5	UNION NUT	2		
4	END CONNECTOR	2	□PVC	
3	CARRIER	1	□CPVC	
2	BALL	1		
1	BODY	1		

2-øS₂ Depth S₃

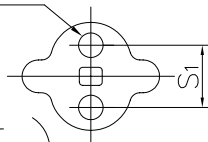

(Detail of holes for insert metal fittings)

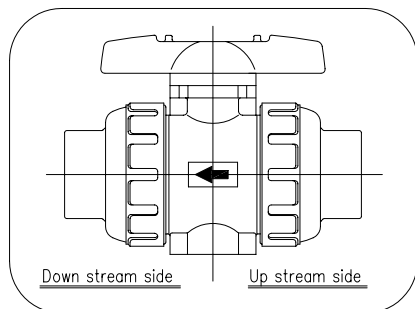

THIS DRAWING AND ALL INFORMATION HEREON IS THE PROPERTY OF ASAHI/AMERICA. ANY COPYING, REPRODUCTION OR UNAUTHORIZED USE IS FORBIDDEN WITHOUT WRITTEN CONSENT.

NAME	DATE
DR KENICHI MIYAZAKI	8/26/02
APPD DAVE HURLEY	8/26/02
PROD LEO LESTER	8/26/02
WO#/CO#	
FILE	

ASAHI/AMERICA
ISO 9001 CERTIFIED
35 GREEN STREET, P.O. BOX 653, MALDEN, MA.

TRUE UNION BALL VALVE
TYPE21 VENTED BALL
1/2" THRU 2"

SIZE	A	DWG. NO.	0104BV	REV	D
SCALE	NTS		SHEET 1 OF 1		